

MH Series Hydrapak® Hydraulic Drive Cooling Systems

FEATURES & BENEFITS

The MH series Hydrapak is the culmination of over 20 years of experience making Hydrapaks for the transportation industry. This experience, along with new technology, state-of-the-art manufacturing methods and a strong desire to remain the industry leader, makes the MH series the most affordable model in our range and the best value in the industry.

WHAT IS A HYDRAPAK?

The Drum Hydrapak is a pre-engineered, highly efficient, hydraulic oil cooling package. It includes the oil reservoir, cooler, return line filter and system relief valve. All components are designed into a small, lightweight, quiet and inexpensive package.

- **10GA, 316 stainless steel mainframe** for durability, long life, and great looks
- **Reservoir** 14 GA, 316 stainless steel double wall construction
- **Integral diffuser** eliminates foaming and vortexing
- **Filler/breather cap** with dipstick
- **Heavy-duty**, corrosion-resistant, high efficiency oil cooler
- **Hydraulic motor driven fan** is factory set for optimum performance
- **Standard spin on filter** with 10 micron element
- **Cartridge style relief valve**
- **Auxiliary tank access** for case drain port
- **-4 (1/4") SAE** gauge port
- **Common parts** with other Drum Hydrapaks



MH1 HYDRAPAK

- **2 gallon reservoir**
- **Only 49 lbs. dry**
- **Flow Rate: Up to 20 gpm**
- **Pressure: Up to 3000 psi**
- **Connections:**
 - High Pressure – 12 (3/4") JICM
 - Low Pressure Return – 12 (3/4") JICM
 - Suction –20 NPTF

MH3 HYDRAPAK

- **4 gallon reservoir**
- **Only 75 lbs. dry**
- **Flow Rate: Up to 40 gpm**
- **Pressure: Up to 4500 psi**
- **Connections:**
 - High Pressure – 12 (3/4") JICM
 - Low Pressure Return – 16 (1") JICM
 - Suction –24 (1 1/4") Code 61 split flange with variety of hose barb options

MH Series – Hydrapak® Hydraulic Drive Cooling Systems

PERFORMANCE CURVE – MH1 HYDRAPAK

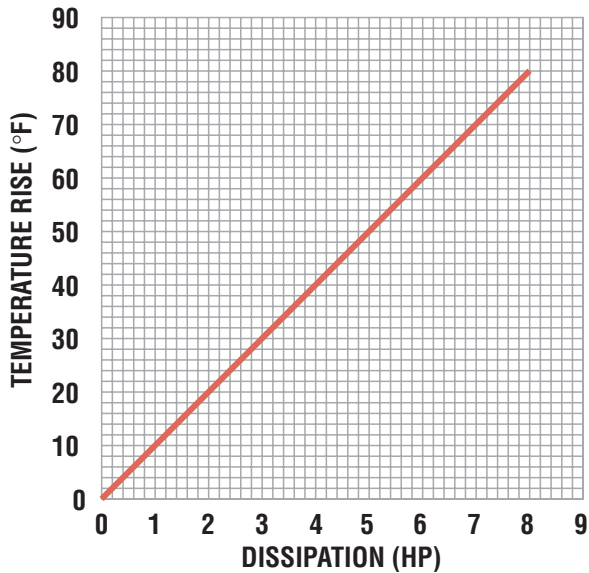

PERFORMANCE CURVE – MH3 HYDRAPAK

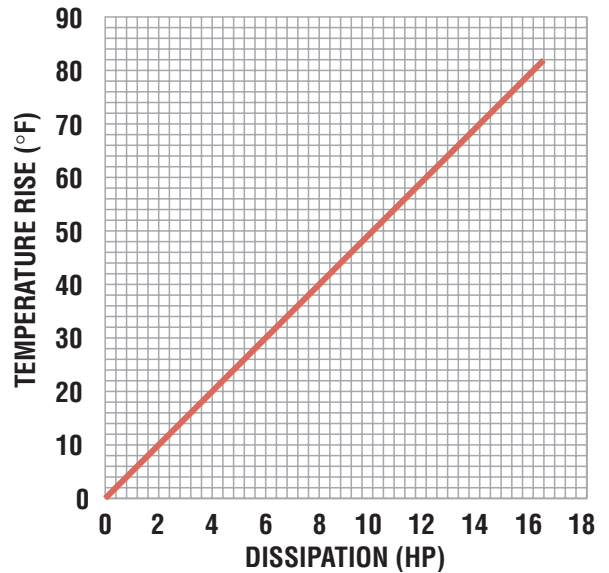

TYPICAL APPLICATIONS

- Crude Oil Transports
- LP Gas Transports
- LP Gas Bobtails
- Food & Chemical Transports
- Bulk Feed
- Lube Trucks
- Maintenance Trucks
- Hydraulic Winch Drives
- Utility Equipment
- Agriculture Equipment
- Mining Equipment
- Water Trucks
- CO2 Delivery Trucks
- Vacuum Trucks
- Live Floor

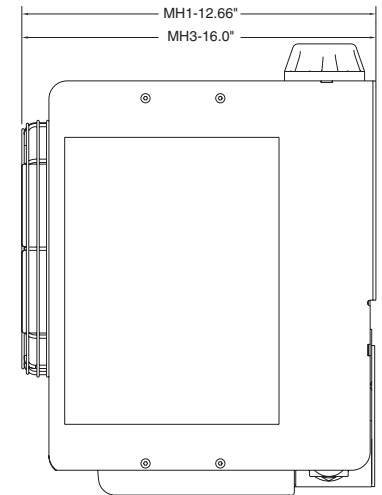
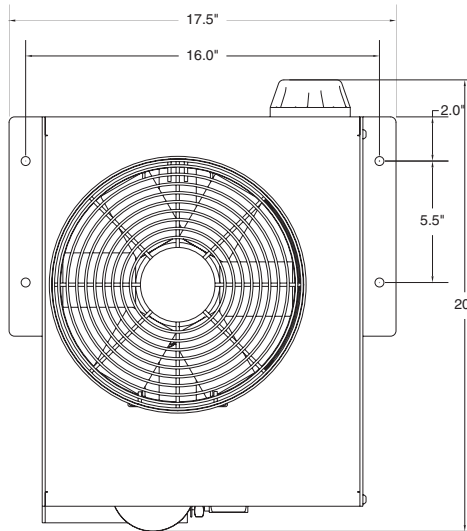

Contact Your Gardner Denver Representative

For additional information, contact your local representative or
Gardner Denver Mobile Solutions

2501 Constant Comment Place • Louisville, KY 40299

Toll Free: 800-626-6334

PH: 502-266-6677 • Fax: 502-266-5873 • www.gardnerdenver.com

E-mail: mobilesolutions@gardnerdenver.com

Visit our web site: www.gardnerdenver.com

For Parts Information, Contact Gardner Denver Customer Service:

Ph: 1-800-626-6334 • Fax 502-266-5873

