

D807 Dry Bulk Truck Blower

The D807 is the most versatile truck blower available. Fitting a D807 on your tractor means it will be ready to do any job necessary, fine powders, food products, large pellets, vacuum loading, anything. Keep your fleet size in control and make dispatching easy. High-pressure capability and wide speed range make the D807 ideal for cement, sand, fly ash, flour, sugar, grain, pebble lime, plastic pellets and more.

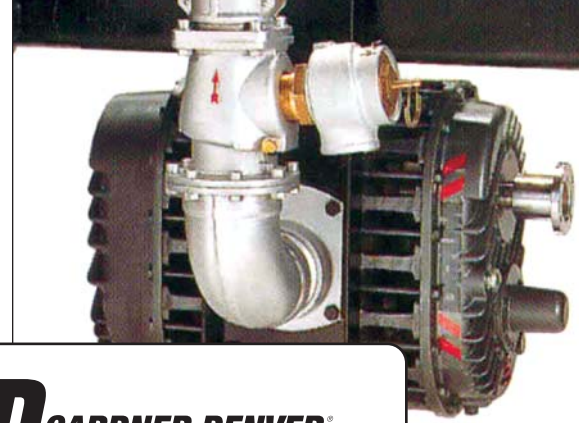

FEATURES

- 20 psi continuous duty pressure rating
- Oil lubrication at both ends reduces bearing temperature and eliminates the need for greasing
- Diamond port design greatly reduces noise and smooths out airflow
- Computer designed ribbing on body, end plates, and gear cases provides cooler discharge temperatures
- Easy Installation with vertical mounting kit
- Twin drive shaft offers either direction of rotation and ensures correct alignment of drive shaft upon installation
- Packaged units available for on-site product transfer requirements
- 12 month warranty

SAFE FROM HEAT AND PRESSURE

- Plug relieves 5-6 psi along with a 60-80°F drop in temperature
- One plug fitted on suction side and one on the delivery side
- Audibly alerts operator when plug melts at 22 psi
- Allows continued operation at lower pressure
- Plug does not eject molten material upon activation
- Consistent release of temperature from each plug



GEARED FOR HIGHER EFFICIENCY

- Dynamically balanced efficient rotor for cooler operation
- Precision ground helical gears keyed to shaft provide positive timing and easy maintenance

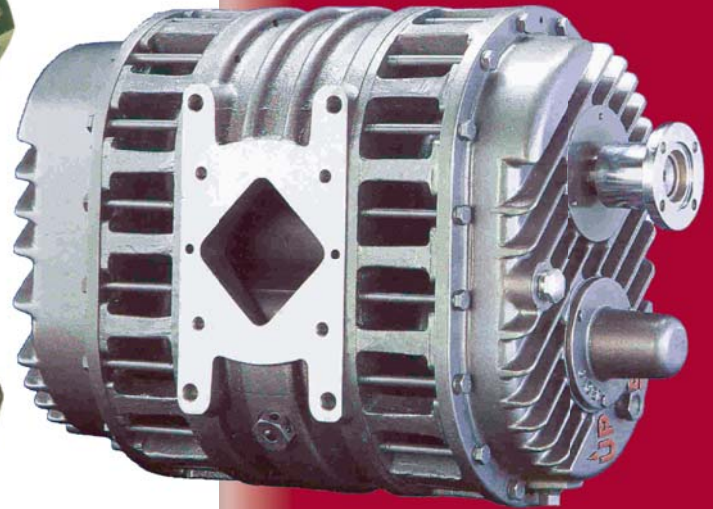

DRUM D807

- Airflow from 390 cfm to 1,000 cfm
- Pressure to 20 psig
- Vacuum to 17 "Hg
- RPM Range from 1600 RPM - 3000 RPM

PERFORMANCE SPECIFICATIONS

Pressure	1800 RPM			2000 RPM			2200 RPM			2400 RPM			2600 RPM			2800 RPM			3000 RPM		
PSI	CFM	HP	CFM	HP	CFM	HP	CFM	HP	CFM	HP	CFM	HP	CFM	HP	CFM	HP	CFM	HP	CFM	HP	
2	578	8	650	9	722	9	794	10	864	11	936	12	1010	13							
4	548	13	620	15	692	16	764	17	838	20	910	21	983	23							
6	525	19	597	21	669	23	741	25	812	28	884	30	956	32							
8	506	24	578	27	650	30	722	32	794	36	865	39	937	42							
10	489	30	561	34	633	37	705	40	776	44	846	47	918	51							
12	473	36	545	40	618	44	690	48	760	52	831	56	903	61							
14	459	42	531	46	603	51	676	56	744	60	816	65	888	71							
16	446	47	518	52	590	58	662	63	730	69	803	74	875	80							
18	435	53	508	59	580	65	652	71	716	77	790	83	862	89							
20	424	59	496	65	568	72	640	78	706	85	778	92	850	98							

Vacuum	1800 RPM			2000 RPM			2200 RPM			2400 RPM			2600 RPM			2800 RPM			3000 RPM		
IN HG	CFM	HP	CFM	HP	CFM	HP	CFM	HP	CFM	HP	CFM	HP	CFM	HP	CFM	HP	CFM	HP	CFM	HP	
2	600	5	693	5	736	6	812	7	884	7	956	8	1030	9							
4	573	8	656	8	714	10	788	11	852	11	934	12	1006	13							
6	545	10	618	11	691	13	764	14	820	15	912	16	982	17							
8	527	13	600	14	673	17	742	18	809	19	891	21	962	22							
10	509	16	582	17	654	20	720	21	798	23	870	25	942	27							
12	482	19	559	21	632	23	697	25	775	27	847	30	919	32							
14	454	21	536	24	609	26	673	28	752	31	824	34	896	36							
16	436	22	515	27	571	29	655	31	732	34	803	38	875	40							
17	418	25	494	29	538	31	636	34	712	37	782	41	854	43							

D807 Dry Bulk Truck Blower

INSTALLATION

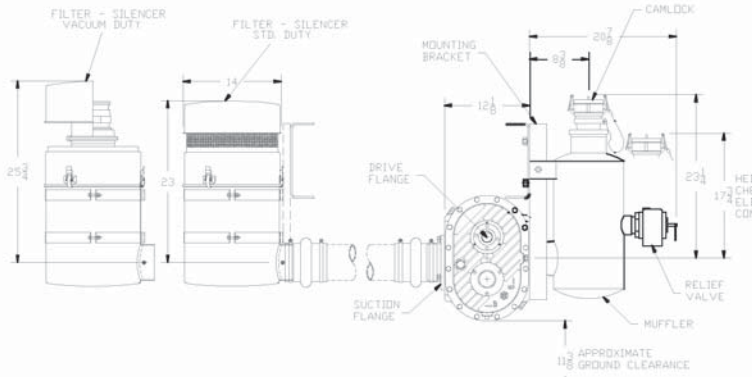

DIMENSIONS

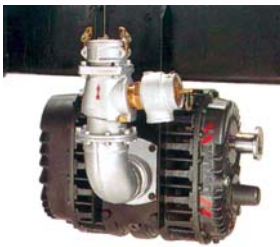
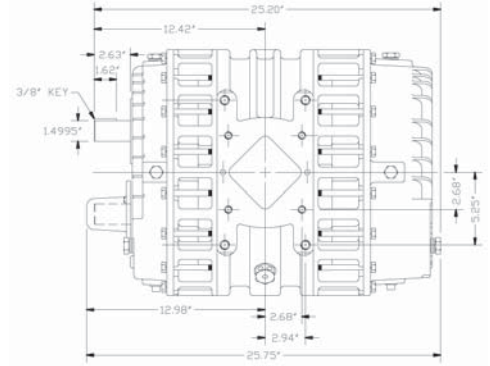

FLEXIBLE MOUNTING KITS

- Lightweight aluminum discharge pipe work
- Spring loaded check valve
- Bolt on camlock 3" or 4" available
- 2" relief valve screws directly in body
- Easy installation using universal mounting bracket
- Drive flange 1300 series



ACOUSTICALLY DESIGNED EASY BOLT ON MUFFLER

- 2" NPT port for relief valve in housing
- Port for optional pressure gauge
- Available in Stainless Steel
- Double wall construction with 1000° F packing totally enclosed to prevent any down line contamination



ACOUSTICALLY TUNED FILTER SILENCER

- Radial filter element giving greater sealing in canister
- Removable foam pre-cleaner element for cleaning and reuse, in addition the foam pre-cleaner greatly adds to noise abatement and service life
- Filter lid and screen designed to give minimal restriction and keep out water
- O-Ring type gasket seals top and bottom assemblies for maximum protection
- Powder coated inside and out
- Restriction indicator available



VACUUM FILTER SILENCER

- Simplicity in design
- Removable screen lid using quick flex latches allows the driver easy access to the 4" camlock

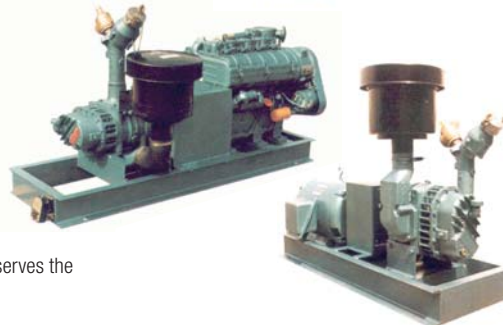

PACKAGED UNITS

Self contained package units with electric motor, diesel engine or hydraulic drive can be supplied.

As a part of a continuous commitment to product development the company reserves the right to alter the specification of its products without prior notice.

Contact Your Gardner Denver Representative

For additional information, contact your local representative or
Gardner Denver Mobile Solutions

2501 Constant Comment Place • Louisville, KY 40299

Toll Free: 800-626-6334

PH: 502-266-6677 • Fax: 502-266-5873 • www.gardnerdenver.com

**Gardner
Denver**

E-mail: mobilesolutions@gardnerdenver.com

Visit our web site: www.gardnerdenver.com

For Parts Information, Contact Gardner Denver Customer Service:

Ph: 1-800-626-6334 • Fax 502-266-5873